



MODERN PERGOLA INSTALLATION GUIDE



TOOLS LIST

- Drill(s)
- 3/8" Magnetic Driver (s)
- 12" Drill Extension
- #2 Square Drive bit for Drill or Driver
- Level
- Tape Measure
- Hammer Drill if necessary for concrete or footing mounts
- Wrench for Anchors on post
- Composite shims
- Quick Clamp(s)
- 3/4" Step Drill Bit (Vari -Bit®) – For reaming holes in aluminum
- Pencil
- Speed Square
- String line

IF CUTTING TO SIZE IS REQUIRED:

- Miter or Circular Saw with carbide blade (cut slowly)
- Sawhorses

ADDITIONAL TOOLS FOR DIGGING AND SETTING PIER TYPE FOOTINGS

- Hand diggers/Auger
- Scrap Lumber (for making forms)
- Concrete stakes (for holding forms)
- Wheel barrow or small concrete mixer
- Shovel
- Trowel

All fasteners for beams, rafters, purlin holders and purlins included in kit

Fasteners NOT provided in kit: Post mount attachment, Ledger plate attachment, Rafter to structure attachment

STEP 1 – LAYOUT

Figure 1

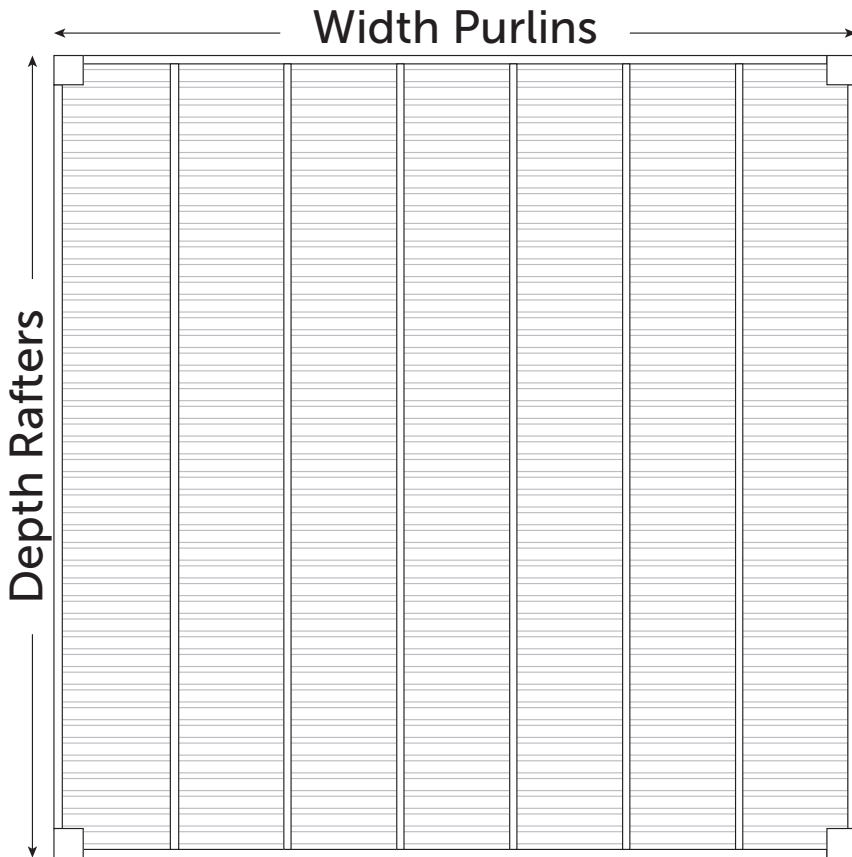

All pergola kits are fabricated to fit the size ordered. They CAN be trimmed to fit a smaller space if necessary. (See Step 1e. below)

a. Determine necessary height and post locations based upon site – Make note of the following measurements as you will want these later:

- a. Desired outside to outside dimensions of your posts
- b. Desired height to the top of your beam
- c. Desired direction of shade purlins and rafters
- d. If you desire to trim the width of your pergola simply determine your ideal size and build accordingly. You can very easily mount posts and trim the appropriate beams and purlins as you follow the installation steps.

e. **IMPORTANT** - If you desire to trim the depth of your pergola you must take into consideration the purlin holders. To avoid having a "half hole" in your roof you should first remove the purlin holder and determine what trim length will allow you to cut between the holes. This same measurement can be then applied to your post mount spacing. You will trim each beam, rafter and purlin holder in your kit by this exact size as you follow the installation steps.

b. **IMPORTANT** - Ensure posts are SQUARE with each other and/or any adjoining structure – **NOTE:** If adding to an existing slab or patio do not assume that they are built square! The best way to determine if things are square is to measure diagonally from post base to post base and adjust until the diagonal measurements are the same. A square post layout will reduce installation time and ensure an excellent fit and finish.

c. It is common that existing concrete and paver patios are installed with a certain degree of slope. If slope is minimal (less than 1" in 10') you can simply disregard it. If slope is more pronounced, consider that your posts may be differing lengths to allow pergola roof to be level to horizon.

d. For challenging sites, custom fabrication of pergolas to your unique site is available, please contact us.

STEP 2 – INSTALL POST MOUNTS

A) MOUNT TO DECK (FIGURE 2A)

- a. Add blocking below deck flooring under each post mount. Minimum blocking thickness of 3" (this is two 2x10's thick)
- b. Inset mount as necessary to ensure the base of post does not overhang edge of decking.
 - i. For standard kits (no post skirt), inset a minimum 1" from deck edge to edge of post mounting plate.
 - ii. For kits with post skirt (10 1/2" square) – inset a minimum 3" from deck edge to edge of post mounting plate.
- c. Detail on nailing blocking – Minimum 4 nails on each side of 2by block

- d. Mount Fasteners – Carriage Bolts or ledger attachment screws (5" or greater)
- e. Use composite shims as necessary to plumb mount. Tighten fasteners.

B) MOUNT TO CONCRETE SLAB OR LANDSCAPE COLUMN TOP (FIGURE 2B)

- f. **NOTE:** For a poured concrete slab or patio, make sure concrete is in good repair For a landscape column we recommend a one-piece cap of concrete or natural stone (4000 psi or greater), minimum thickness 2.25". It is important that the post is constructed on a sound

foundation. For a compacted gravel base, this means a minimum two courses below grade. For a concrete base, be sure to attach footing to base course with the recommended amount of landscape adhesive. For construction of post, we recommend either masonry or a high-quality concrete product installed with a quality brand of landscape adhesive. In the case of adhesive, follow manufacturer's instructions. For added strength you can also fill the pillar(s) with concrete or mortar to add weight and rigidity.

- g. Inset mount as necessary to ensure the base of post does not overhang edge of concrete.
 - i. For standard kits (no post skirt), inset a minimum 3" from edge of mounting surface to edge of post mounting plate.

Figure 2a

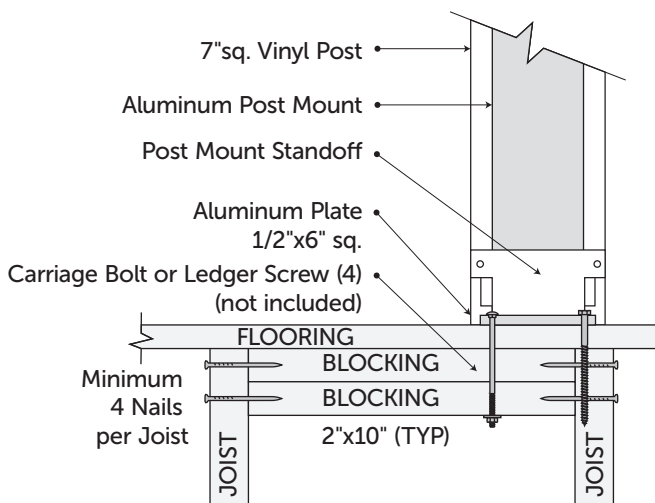
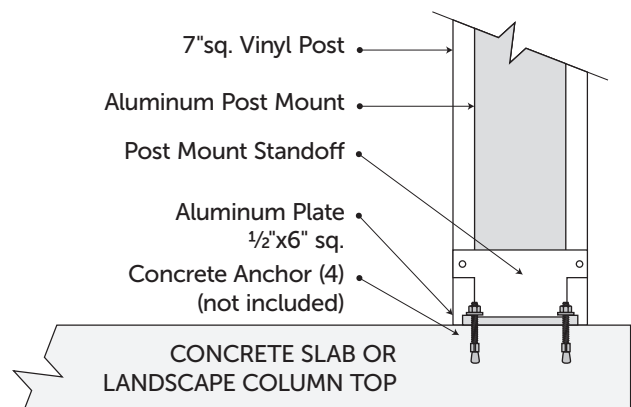

Figure 2b



- ii. For kits with post skirt (10 1/2" square)– inset a minimum 3" from edge of mounting surface to edge of post mounting plate.
- h. Mount Fasteners - 3/8" hot dipped galvanized wedge or screw type anchors, minimum 2" embedment.
- i. Use composite shims as necessary to plumb mount. Tighten anchors.

C) MOUNT TO FOOTING – FOR PAVER PATIOS OR APPLICATIONS WITHOUT A

Figure 2c

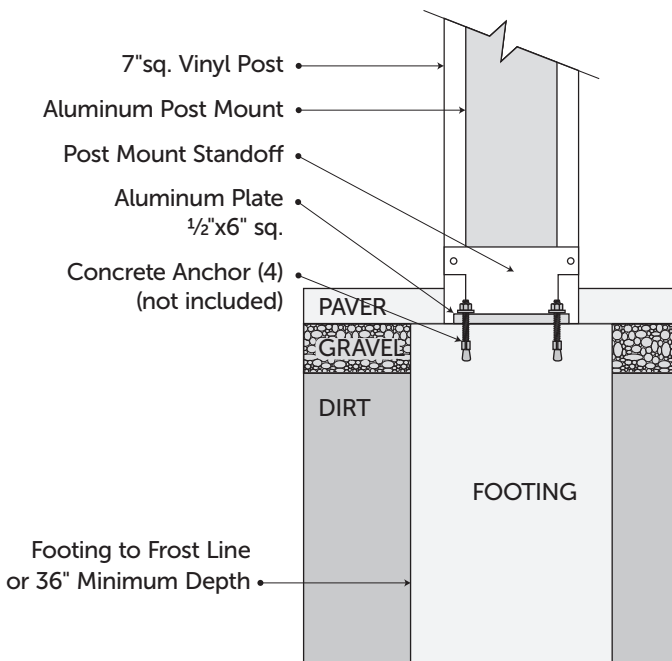

SOLID SURFACE TO FASTEN TO (FIGURE 2C)

- j. The main goal in this method is to discretely isolate the pergola posts from the patio area. This allows the patio to move up and down over the seasons while the pergola posts stay plumb and level. To do this properly, we recommend that the footing height be at least one paver thickness below the finished grade of the patio.
- i. If there is an existing patio, you can simply remove blocks as necessary to form and pour footings to the height just below the existing patio surface. Use a concrete saw to cut the paver blocks to fit around the post once the forms are removed.

ii. If the patio is not yet installed, you MUST establish the desired patio surface height prior to forming and pouring your footings. The end goal is that the patio block will fit neatly around the post without fitting under it. This allows the patio to freely move up and

down without squeezing or crushing parts of the pergola post. **NOTE:** It is common that the patio will have some slope. This is no problem. Simply set the top of your forms to follow the desired slope. The roof of the pergola can still be installed level.

- k. Determine post locations and layout with strings and tape measures.
- l. Minimum footing size = 12" round or 10" square.
- m. Dig footings to frost line, making sure to remove excess loose dirt from the bottom of the hole. In regions without a seasonal freeze thaw we recommend a minimum 36" footing depth.
- n. If the desired top of the footing needs to be above the ground around it, build, stake and level forms over your holes. Ensure your forms are installed square to patio or structure. It is often helpful to set string lines to double check the locations as well as desired height of the footings.
- o. Fill holes with concrete to top of forms and trowel smooth
- p. Once cured, attach post mounts to footings using 3/8" dia. hot dipped galvanized wedge or screw type anchors, minimum 2" embedment. Use composite shims as necessary to plumb mount. Tighten anchors.

STEP 3 – INSTALL POSTS OVER POST MOUNT

- Double check desired height of pergola roof and mark each aluminum post mount at the **top** of the beam – simplest way (short of using a laser level) is to quick clamp your beams to your post mounts and mark the mount at the desired height.
- Cut aluminum post mount 8 ½" below this mark** - Use any circular saw with a non-ferrous blade. It is important that the cut be as square as possible. This will help the Post Top Plate to sit level. We recommend that you trace your cut line around the post with a speed square.
- Slide the Post Mount Standoff over each post. These provide a friction tight fit between the post and post mount. They will sit on the top of the post mount plate and do not need to be fastened.
- Insert the Post Top Plate into the top of your post mount.
- Attach Post Top Plate to the post mount with fasteners labeled "post top plate to post mount". This connection provides a surface to attach your pergola box beams and prevents uplift of your post under high winds.
- Cut 7x7 vinyl post to proper height – First measure from the base of post mount to the top of the Post Top Plate. Cut your vinyl post 9" longer than this measurement.
- Make sure to cut from the correct end of the post.** This is the end without the routed slot for the beam.
- Remember, your vinyl post will stick up 1" taller than the top of the 2x8 box beam to allow room to fit in the post cap.
- If the bottom of your post will be visible upon completion you will want to take extra time to ensure to cut the post off as square as possible. This is best done by tracing your cut line around the post with a speed square and cutting carefully and slowly.
- Slide the post over the top of the mount. If you purchased the post skirts, slide those over the post next.
- Repeat this step for each post.

STEP 4 – ATTACH LEDGER TO STRUCTURE

ATTACHED PERGOLAS ONLY

- Secure ledger to structure ensuring it is centered on pergola
- Fasteners – Necessary fasteners for Ledger are NOT provided in kit. Requirements determined by structure.
- If removing siding, ensure that ledger plate is properly flashed and sealed.
- If ledger is installed over top of siding, ensure that top and sides are caulked adequately.

Figure 4

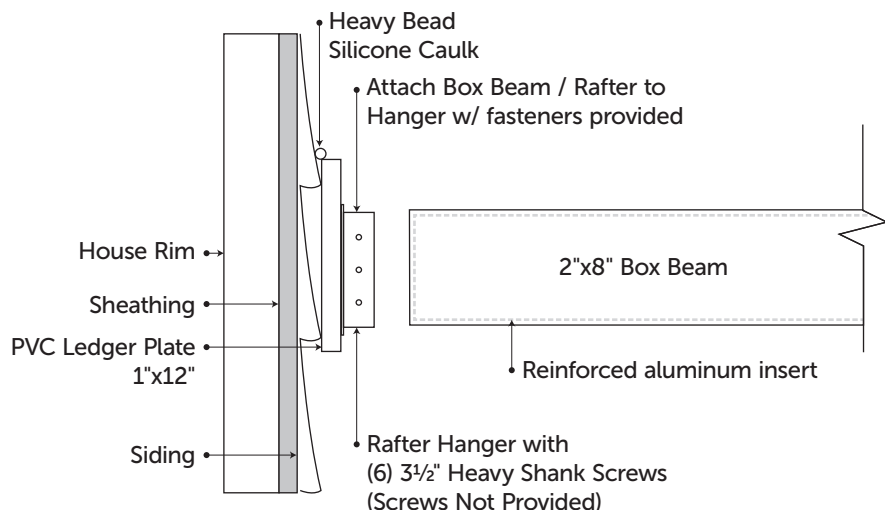

STEP 5 – INSTALL PERIMETER BOX BEAMS (FREESTANDING PERGOLA)

- If you trimmed the width or depth of your pergola follow items 1-3 below. If not proceed to letter b) below.
 - Plan out the length of each box beam (2x8) according to figure 5a. Note that freestanding and attached pergolas have different methods of lapping the beam.
 - Start by measuring at the post base, the outside to outside of each post on your pergola (Figure 5a). Write these down on the top of each box beam.
 - Cut the beams 2 ½" under this measurement.**
- Using the step bit drill two large holes in the top of each beam according to figure 5b. No need to worry about cosmetics here, these holes will be covered later.
- Using a helper, lift and set the beams into your posts ensuring to lap the beams as per figure 5a.
- Using your driver and 12" extension, fasten the beam to the Post Top Plate using the fasteners labeled "beam to post".
- Set the beam attachment bracket in the inside corner of each beam intersection (Figure 5b).
- Using a driver extension and the pre-drilled holes in the post, attach each bracket to post stiffener with fasteners labeled "beam attachment bracket" You DO NOT need to fill every hole on the bracket, four per side is sufficient.
- Insert the post cap into each post. This cap should sit ¼" below the top edge of the post.
- Fasten the post cap to the top of the box beams with fasteners labeled "post cap."
- Install 5/8" plugs into the holes on the side of the post.
- Repeat this step for each beam and post connection.

Figure 5a

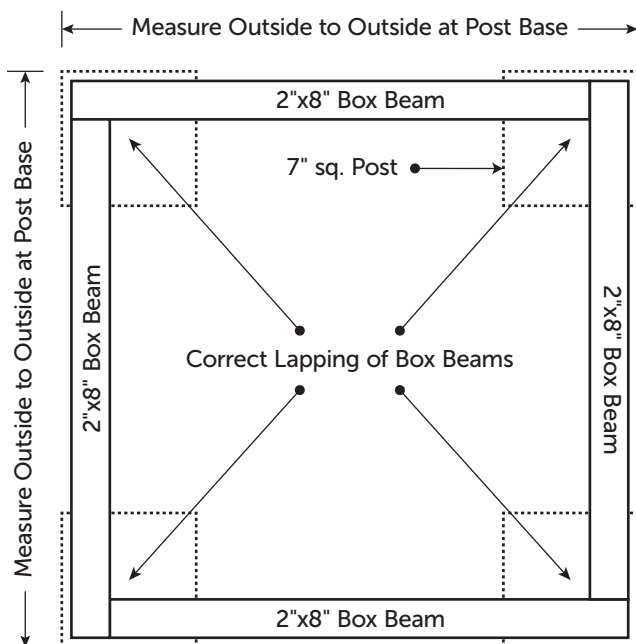
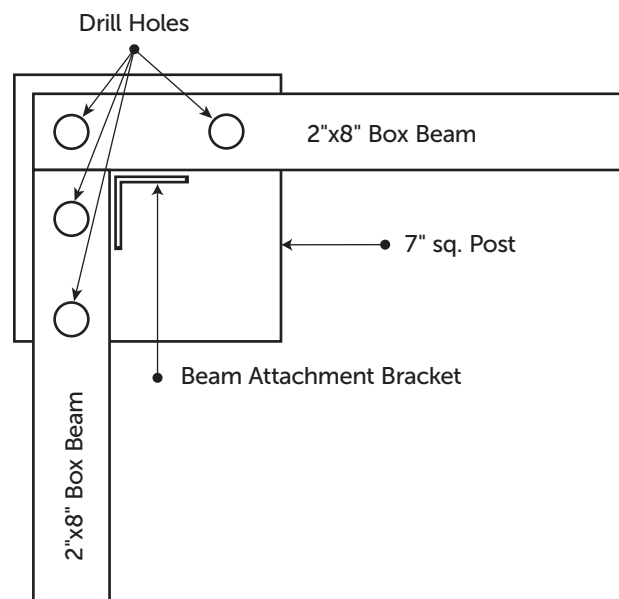

Figure 5b



STEP 5 – INSTALL PERIMETER BOX BEAMS (ATTACHED TO STRUCTURE METHOD)

- a. If you trimmed the width or depth of your pergola follow items 1-4 below. If not proceed to letter b) below.
 1. Start by measuring, at the post base, the outside to outside of the posts as shown in figure 5c. Write this measurement on top of the corresponding box beam (2"x8).
 2. **Cut this beam ½" under the outside to outside post measurement.**
 3. Measure the outside of post to ledger plate (already attached to structure) for the remaining two openings. Write this measurement on the top of each box beam.
4. **Cut these beams 2 ½" under this measurement.**
 - b. Using the step bit, drill two large holes in the top of each beam end according to figure 5b. These holes will be covered later. DO NOT drill holes on the side of the beam that attaches to the structure.
 - c. Install the rafter hanger on the ledger plate for each of the box beams attaching to your structure. **NOTE:** Necessary fasteners for ledger plate attachment are NOT provided in kit. Requirements determined by structure.
- d. Using a helper, lift and set the beams into your posts and hangers ensuring to lap the beams as per figure 5c.
- e. Using your driver extension fasten the beam to the Post Top Plate using the fasteners provided.
- f. Set the beam attachment bracket in the inside corner of each beam intersection (Figure 5b).
- g. Using a driver extension and the pre-drilled holes in the post, attach each bracket to box beam with fasteners labeled "beam attachment bracket" You DO NOT need to fill every hole on the bracket, four per side is sufficient.

Figure 5c

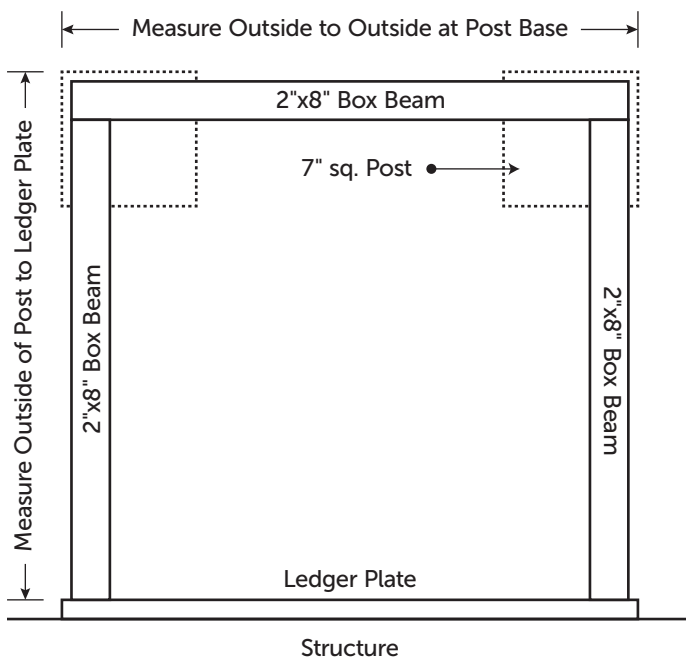

- h. Insert the post cap into each post. This cap should sit ¼" below the top edge of the post.
- i. Fasten the post cap to the top of the box beams with fasteners labeled "post cap."
- j. Install 5/8" plugs into the holes on the side of the post.
- k. Fasten outside beams to rafter hanger using fasteners labeled "rafter hanger to rafter." DO NOT put a screw in the top hole on the inside of the box beam as it will interfere with the outside purlin holder in step 7.
- l. Repeat this step for each beam and post connection.

STEP 6 – INSTALL RAFTERS

- a. Measure from the outside of one box beam to the other. This measurement will be divided evenly depending on the number of rafters in your kit. Example (Figure 6): If you have a 16' wide kit you will have six rafters and seven spaces. The measurement from the outside of your box beams should be around 191". Subtracting 2" will give us the center to center measurement. $191" - 2" = 189"$. We will then divide 189" by seven spaces to get 27". This is the center to center measurement of each rafter. If you have NOT trimmed your pergola width this center to center measurement will be called out in the CAD drawing for each pergola size.
- b. Using this measurement, mark the center of each rafter on each of the beams.
- c. Using the fasteners marked "rafter hanger to beam", and the rafter hanger tool included with your kit, install the rafter hangers on these marked locations. The rafter hanger tool will ensure the proper height of each rafter on the beam. If your kit is attaching to a structure, please note that these fasteners are NOT provided in your kit as they are determined by the type of structure you are attaching to.
- d. If your kit is attached to a structure, you will want to transfer the same rafter spacing layout you used on your outside box beam to the ledger plate on the structure. To ensure the rafter hangers are placed at the correct height it is helpful to use a stringline attached with quick clamps to the box beams next to the structure. If you pull this line tight under the box beams it will show the correct line for the bottom of your rafter hangers.
- e. If you trimmed the depth of your pergola please follow items 1-2 below, If not proceed to letter e) below.
 1. Measure each opening between hangers to determine the rafter length. Write this on the top of each rafter.
 2. **Cut each rafter ½" shorter than this measurement.**
- f. Using a helper, lift and set each rafter into place, and attach with the fasteners labeled "rafter hanger to rafter".
- g. Repeat this step for each rafter and connection

Figure 6

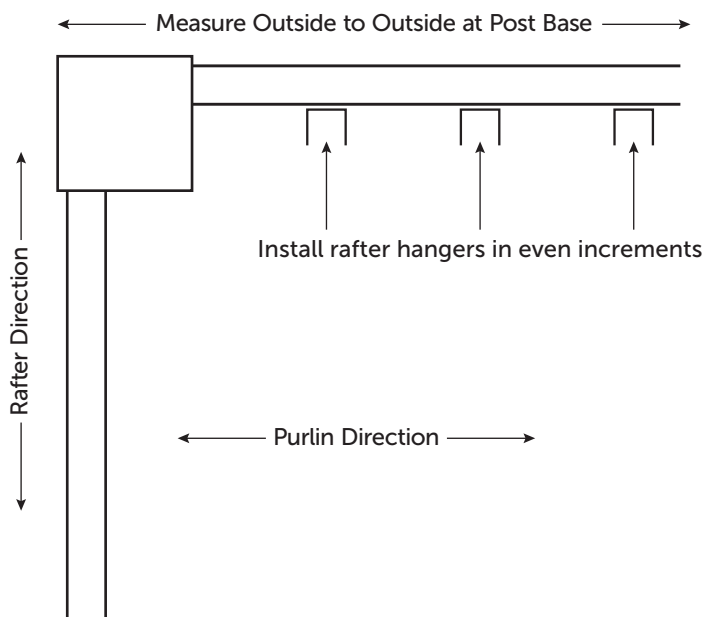

STEP 7 – INSTALL PURLIN HOLDERS

- a. First, install one of the outside purlin holders (2" x 3 1/2") to your box beam. Measure the correct length of these according to figure 7a. – **IMPORTANT** - Make sure to consider which direction you would like to purlins to angle to provide your desired amount of shade.
- b. If necessary, cut outside purlin holders to fit tightly between the posts as in Figure 7a. **IMPORTANT** - cut each holder from the side marked CUT END. If you cut the wrong end it will be difficult to later line up the holes.
- c. Attach outside purlin holder to the box beam using the fasteners labeled "outside purlin holder to box beam." Make sure the height of the top of the holder matches the top of the beam.
- d. Install 5/8" plugs into the holes on the outside purlin holder.
- e. If necessary, measure and cut inside purlin holders (1 3/4" square) to fit on the top of each rafter. Make sure to cut from the end labeled CUT END.
- f. Using the fasteners labeled "inside purlin holders to rafter", Install these 1 3/4" purlin holders on top of each rafter. **IMPORTANT** -
 - a. Be careful not to OVERTIGHTEN these screw as they can crack the purlin holder. It is helpful to turn down the speed of your drill.
 - b. Make sure purlin holes are angled the same direction as the outside purlin holder.
- c. Make sure that your screws are spaced BETWEEN the holes for the purlins.
- d. Install a screw near each end and one about every 2' along the purlin holder. It is helpful to count the number of holes on the holder and space the screws evenly between
- g. **DO NOT** install the remaining outside purlin holder on the other end. This happens AFTER the purlins are installed.

Figure 7a

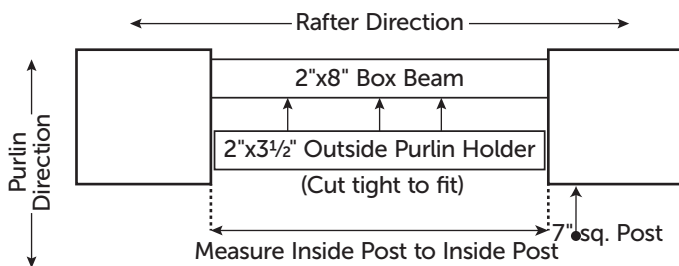
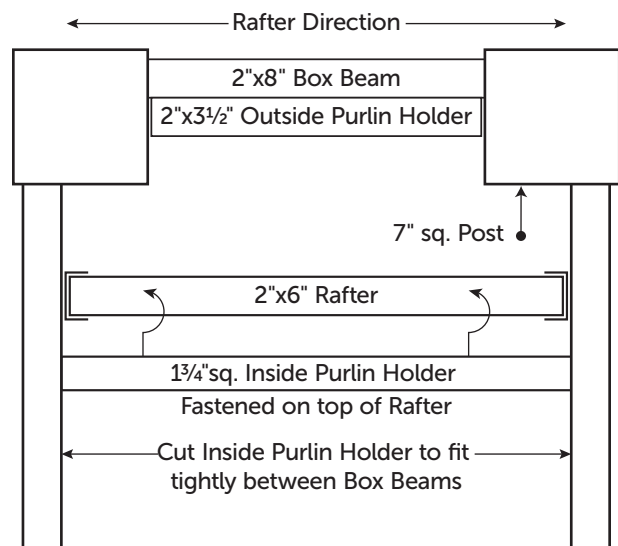

Figure 7b



STEP 8 – INSTALL PURLINS

- a. **NOTE:** There are two purlins with your kit that are cut shorter than the rest. These fit in the purlin holes between your posts and are the first and last purlins on the pergola.
- b. If you trimmed the width of your pergola, follow items 1 & 2 below. If not proceed to letter c) below.
 1. To determine proper purlin length, insert a tape measure into the outside purlin holder and measure to the inside of the last box beam. **Cut purlins 1 ½" shorter than this measurement.**
 2. For first and last purlins, cut enough off to fit between your posts. This should be 12" shorter than the other purlins.
- c. Install one purlin cap on the end of each purlin.
- d. Before sliding in your purlins, remove the screws from the first 2x6 rafter, closest to the side from which you will be sliding in the purlins.
- e. Raise this rafter enough to slide the piece labeled "rafter block" between the bottom of the rafter and the rafter hanger. This block raises the rafter enough to allow much easier installation of the purlins and remaining outside purlin holder.
- f. Starting at one end with the first purlin, slide the capped end into the holders until it is centered between the posts. **NOTE:** The purlin caps help guide the purlins into each of the holes. It is helpful to have another person to assist with any purlins that get hung up during this process.
- g. Continue sliding purlins (cap end first) in to each hole until fully inserted.
- h. Insert the shorter last purlin into the last hole centering it between posts as you did the first purlin.
- i. Install two additional purlin caps on the ends of the first and last purlin. These can be fastened to the purlin holder (one on each end of the purlin) with the screws labeled "purlin holder to purlin".
- j. Once all purlins are inserted you can install the remaining outside purlin holder. Slide it on the ends of the purlins and gently remove the rafter block from under each end of the first rafter.
- k. Once all the purlins are inserted into the last holder you may need to tap the outside purlin holder down into place. Then align and screw it to the outside beam with the fastener labeled "outside purlin holder to box beam".
- l. Install 5/8" plugs into the holes on the outside purlin holder.
- m. Re-install the screws in the 2x6 rafter that you loosened to insert the rafter block.
- n. Peel off any remaining stickers and clean off any handling or pencil marks with the Magic Eraser®.

CONGRATULATIONS!

Your pergola is now complete and you likely deserve a cold beverage!

OPTIONAL – FAN MOUNT

- a. Use a qualified electrician for rough in during pergola construction. You will need a loop of electrical wire pulled into one of the rafters that the fan mount will be attached to.
- b. **NOTE:** The mount can be installed anywhere from the top to the bottom of the rafter. For more head clearance with the fan, install hangers towards the top of the rafter. Ensure that you leave enough room for the skirt to slide over the rafter hanger.
- c. Once height is determined, attach rafter hangers horizontally with fasteners labeled "fan mount."
- d. Carefully drill through the center hole in the rafter hanger into the rafter to access the loop of wire for the fan.
- e. Pull wire through the hole in the rafter hanger.
- f. Measure the clearance between the rafter hangers.
- g. Cut aluminum and vinyl 2x6 piece 1/8" shorter than the distance between hanger plates, to ensure enough room to fit the 2x6 into place. Test fit the 2x6 between the hangers, trim if necessary.
- h. Once 2x6 is the proper length, mark and drill a hole for the wire to come through the 2x6.
- i. Slide skirts over each end of the 2x6 and test fit the mount in place.
- j. **NOTE:** The skirts must be turned the correct way to fit properly into the rafter hangers. If they do not lock into place, covering the hanger, try removing them and flipping them 180 degrees.
- k. Fish wire through and out of the 2x6 carefully to avoid damaging the sheath.
- l. Fasten each end of the 2x6 with fasteners labeled "fan mount."
- m. Slide the skirts into place.
- n. The mount is now ready for your fan.

